

DILATATION STRIPS

IZOflex® DP

CHARACTERISTICS

IZOflex DP is a strip made of foamed polyethylene.

APPLICATION

1. It is a dilatation strip designed for elimination of the thermal expansivity mainly at installation of floor heating and laying screedings.
2. It is a permanently elastic filling material of dilatation rifts decreasing the transfer of noise and heat from the floor onto the vertical constructions.

PROPERTIES

Volume weight (STN 64 5411)	25-33	Kg.m ⁻³
Increase of the index of soundproofing by footsteps (STN STN 73 0513)	dB	20
Absorptivity in water STN 64 5421	Max. 8	%
Renitence, STN 64 5441	Min. 29	Kpa
Temperature range of use	-40 ≈ +90	°C
Thermal conductivity, STN EN ISO 84 97	0,04	W/m ⁻¹ .K ⁻¹

ASSORTMENT AND PACKAGE

	Width of the stripe	
	100 mm	150 mm
8 mm thick	25 m/ pack	25 m / pack
10 mm thick	25m / pack	25 m / pack

ADVANCES

- 1. Permanently flexible material** – the dilatation stripe transfers the differences in size of the concrete socket and it prevents the deformation of the vertical construction.
- 2. Simple installation** – the stripe shall be stuck on the wall through self-adhesive tape, which is on the reverse side of the dilatation stripe
- 3. Sound insulation** - the dilatation stripe prevents from transfer of the sound of footsteps from the floor onto the construction.
- 4. Heat insulation** – it prevents from arising of heat bridge between the floor and the walls. This feature is especially important at floor heating.
- 5. Ecologically and hygienically perfect material** – at production of foam – polyethylene no ecologically harmful materials are used. The foam–polyethylene after building in other materials does not emit any harmful materials.

OPERATING SEQUENCE

- Izoflex DP is usually stuck on the wall by a glue.
- The wall or the construction on which the dilatation strip is stuck must be cleaned from dust and grease.
- The dilatation strip has to be stuck on the surface in a way that the concrete will not leak in, and no heat or sound bridges will arise.
- After concreting cut the dilatation stripe by a sharp knife.

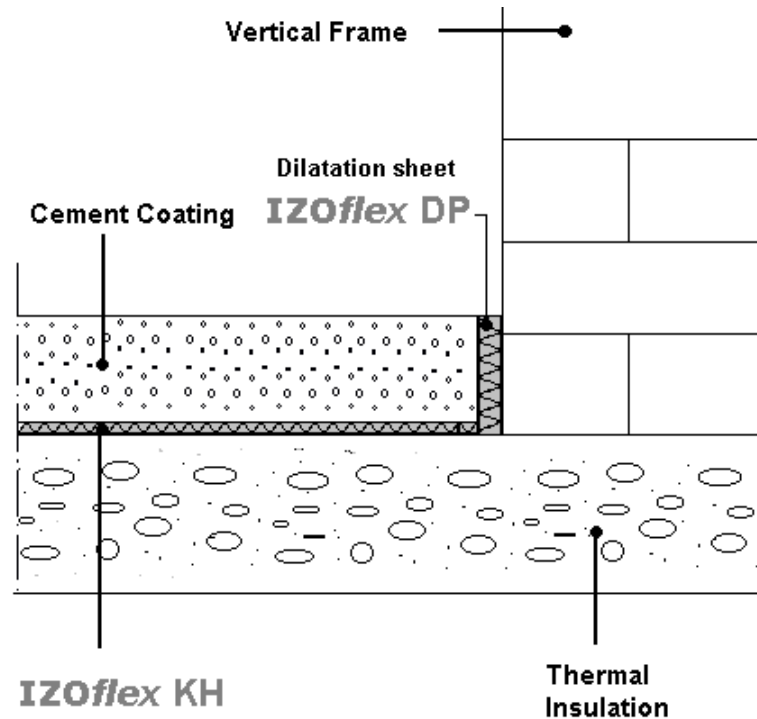

1.1. APPLICATION FOR SCREEDING

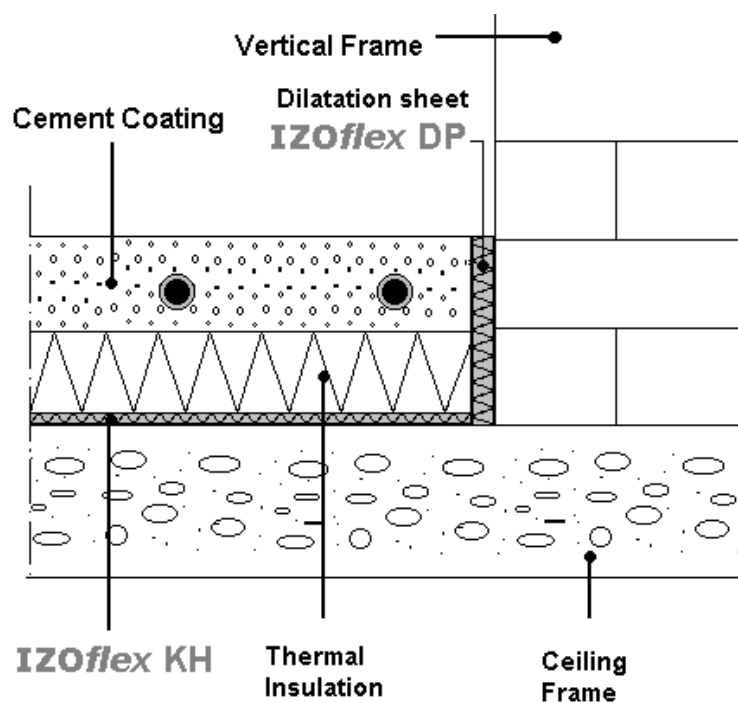

1.2 APPLICATION FOR FLOOR HEATING